

# TROWELS



SOLUTIONS THAT LAST



## WALK-BEHIND TROWELS

To function properly, power trowels must maintain a precise perpendicular relationship between the gearbox's output shaft and blade arms. Once that relationship is compromised, the trowel will vibrate and/or wobble. MBW has gone to great lengths to maintain this critical relationship.



**MBW Walk-Behind Power Trowels** feature the industry's heaviest bearings, output shafts, gears, spiders and blade arms. Comparison of these critical MBW components to those of any competitor answers the question as to why MBW trowels run so well for so long.

## GEAR BOX

Designed for our heaviest trowel, the MBW gear box is overbuilt and preserves component commonality throughout the range. Housing and covers made of heat-treated cast aluminum alloy feature reinforced construction. Cooling fins insure rapid heat dissipation for extended bearing and lubricant life. MBW's one piece, case hardened wormshaft is the most accurate in the industry. Ground bearing journals insure exact bearing alignment and maximum bearing life. All MBW bearings are able to accept load spikes and provide long life under rigorous use. MBW bronze wormgear conforms to exacting specifications and features extra heavy-duty hub and flange construction. High quality seal and O-rings provide resistance to leakage and enhances life of the industry's most rugged gear box.

Precision alignment, serviceability, and resistance to application induced bending or wear, characterize MBW's spider assembly. An entire battery of numerically controlled metal working machinery and in-process inspection procedures allow no compromise on tolerances. Other alignment considerations include Teflon lined, steel arm/bore inserts, and arms which are precisely milled to provide the most accurate blade-to-arm alignment. All components subject to high levels of stress are overbuilt: heavier trowel arms (both hex and machined sections), tilt arm and spider castings, and yoke plates. The pressure plate features a deep collar for added support on spider. Yoke plate is designed for widest dispersal of tilting pressures and is machined to accept a greasable thrust bearing. The most serviceable, precisely aligned, and rugged trowel on the market today.

## F24/4 WALK-BEHIND TROWEL

Ideal for jobs that require a lightweight, highly maneuverable, professional finishing tool, these specialty finishing power trowels allow professional results even when confined areas or weight restrictions leave other machines standing idle. Perfect for edging in the tightest spaces, the **F24/4 Walk Behind Power Trowel** is always ready when needed.

| SPECIFICATIONS | F24/4                      |
|----------------|----------------------------|
| Engine Options | Honda GX120<br>4 hp (3 kw) |
| Weight         | 125 lbs<br>(57 kg)         |
| Height         | 22.5 in<br>(57 cm)         |
| Ring Diameter  | 24 in<br>(61 cm)           |
| Trowel Speed   | 50-135 rpm                 |

( ) Metric Measurements.  
Specifications subject to change without notice.

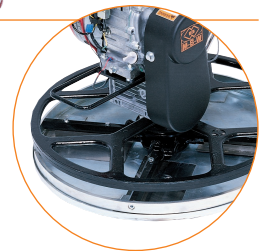

### Rotating Guard Ring:

The rotating guard ring allows operators to finish flush with walls. Precision bearings ensure consistent operation of guard ring.



### Fold Down Handle:

Unique fold down handle makes transportation simple and allows for carrying units up and down stairs.

## F36/4 & F46/4 WALK-BEHIND TROWELS

Operator comfort, safety and increased productivity are essential considerations in the MBW trowel. For example, our handles are up to 6" longer than most competitors for greater leverage. They are adjustable to fit the operator more comfortably and absorb trowel torque.

All handle materials are heavy gauge and do not require gusseting at critical fastening points. Each MBW trowel is balanced with regard to engine location for excellent performance and reduced operator fatigue.

MBW's heavier handle and stronger guard ring add up to extra safety. Our kill switch is fully enclosed and constructed of durable materials with wire and cables housed at their most vulnerable positions. Basic operating and safety instructions are prominently displayed.

Solid throttle wire housed in low friction Teflon-lined casing for smooth operation and low maintenance. Galvanized, braided steel tilting cable is drawn over low friction pulleys within handle/clevis assembly and is securely attached to yoke at swiveling pin. No wear surfaces to snag or abraid cable. Handle, kill switch, rotating and stationary guardings industrial chrome plated for easy cleaning and corrosion resistance.



F36/4

| SPECIFICATIONS | F36/4                          | F36/4                        | F36/4                       | F46/4                        | F46/4                         | F46/4                       | F46/4HD                       |
|----------------|--------------------------------|------------------------------|-----------------------------|------------------------------|-------------------------------|-----------------------------|-------------------------------|
| Engine Options | Honda GX160<br>5.5 hp (4.1 kw) | Honda GX270<br>9 hp (6.7 kw) | Robin EX17<br>6 hp (4.5 kw) | Honda GX270<br>9 hp (6.7 kw) | Honda GX390<br>13 hp (9.7 kw) | Robin EX21<br>7 hp (5.2 kw) | Honda GX390<br>13 hp (9.7 kw) |
| Weight         | 163 lbs<br>(74 kg)             | 191 lbs<br>(87 kg)           | 170 lbs<br>(77 kg)          | 224 lbs<br>(102 kg)          | 237 lbs<br>(108 kg)           | 220 lbs<br>(100 kg)         | 295 lbs<br>(134 kg)           |
| Height         | 26.5 in<br>(67 cm)             | 27 in<br>(69 cm)             | 27 in<br>(69 cm)            | 27 in<br>(69 cm)             | 28 in<br>(71 cm)              | 27.5 in<br>(70 cm)          | 29.5 in<br>(75 cm)            |
| Ring Diameter  | 36 in<br>(91 cm)               | 36 in<br>(91 cm)             | 36 in<br>(91 cm)            | 46 in<br>(117 cm)            | 46 in<br>(117 cm)             | 46 in<br>(117 cm)           | 46 in<br>(117 cm)             |
| Trowel Speed   | 70-135 rpm                     | 70-135 rpm                   | 70-135 rpm                  | 70-135 rpm                   | 70-135 rpm                    | 70-135 rpm                  | 70-135 rpm                    |

( ) Metric Measurements.  
Specifications subject to change without notice.

### Cast Aluminum Alloy Housing

features reinforced construction and cooling fins for rapid dissipation of heat

### Vertical Shaft Assembly

has heavier flange and hubs for greater shaft support. Heavy duty high load capacity bearings add to gear box longevity

### Worm Shaft Assembly

precision machined from solid stock. Bearing journals are precision ground for proper fit and preservation of internal bearing tolerances 1230 lbs. – radial load capacity

### Hex to Blade Matting Surface

is precision milled for near perfect blade alignment

### Teflon Lined Steel Bore Inserts

that will not pound out causing alignment problems

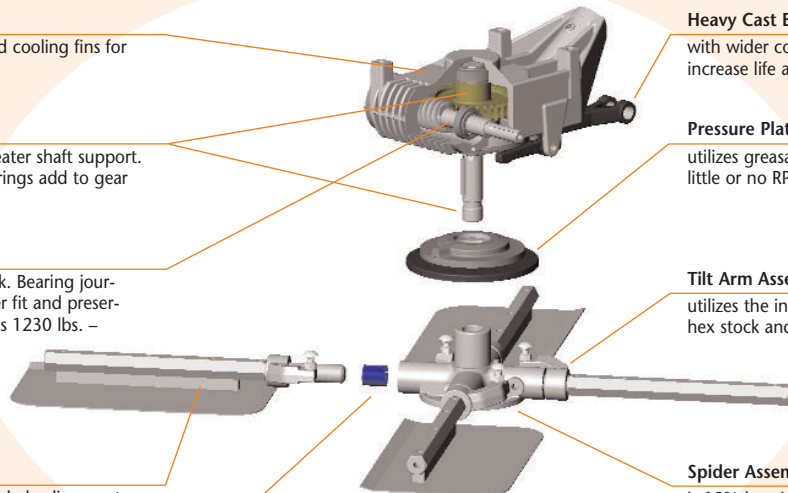

### Heavy Cast Engagement Yoke

with wider construction and no wear points increase life and control of blade adjustment cable

### Pressure Plate Assembly

utilizes greasable thrust bearings to provide little or no RPM variation

### Tilt Arm Assembly

utilizes the industry's heaviest material both in hex stock and larger diameter machined ends

### Spider Assembly

is 15% heavier than competitive models with thicker walls around all bores. Industrial grade 45 degree grease fittings and hardware throughout machine ensures long life



1-800-678-5237



## TROWEL OPTIONS



### Custom Blades and Pans:

Custom blades and pans offer lasting choices. Select from finish, combination or "snap-on" float blades to match your applications. All blades are manufactured from the highest grade, abrasion resistant tool steel.

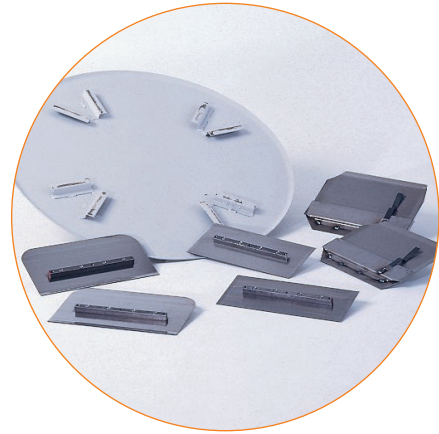

### Constant Force Pitch:

MBW's constant force pitch allows for quick blade adjustment and positive engagement. The constant force spring provides the smoothest and fastest blade adjustment.

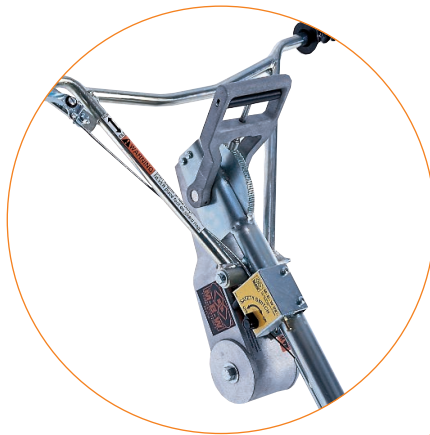

### Edger:

Adjustable guard ring option offers operators the ability to finish within 1/8" of walls, eliminating costly hours of handwork.

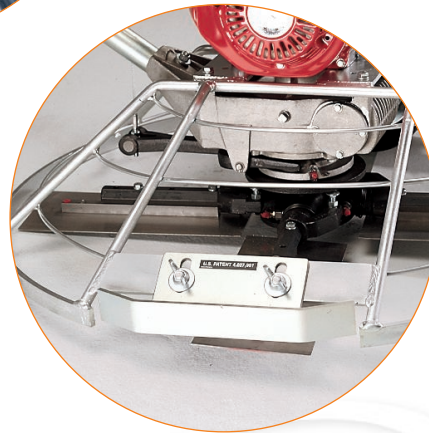

**MBW Inc.**  
250 Hartford Road • P.O. Box 440  
Slinger, Wisconsin • 53086-0440 • USA  
800-678-5237  
262-644-5234  
Fax: 262-644-5169

E-mail: [mbw@mbw.com](mailto:mbw@mbw.com) • Website: [www.mbw.com](http://www.mbw.com)

**MBW UK Ltd.**  
Units 2 & 3 Cochrane Street  
Bolton BL3 6BN • England UK

44 (0) 1204 387784  
Fax: 44 (0) 1204 387797

E-mail: [mbwuk@btinternet.com](mailto:mbwuk@btinternet.com) • Website: [www.mbw.com](http://www.mbw.com)

**AUTHORIZED DISTRIBUTOR**